

FIX POINT BAR KIT

TOYOTA RAV 4 (XA50) 2018→

SUZUKI ACROSS 2020→

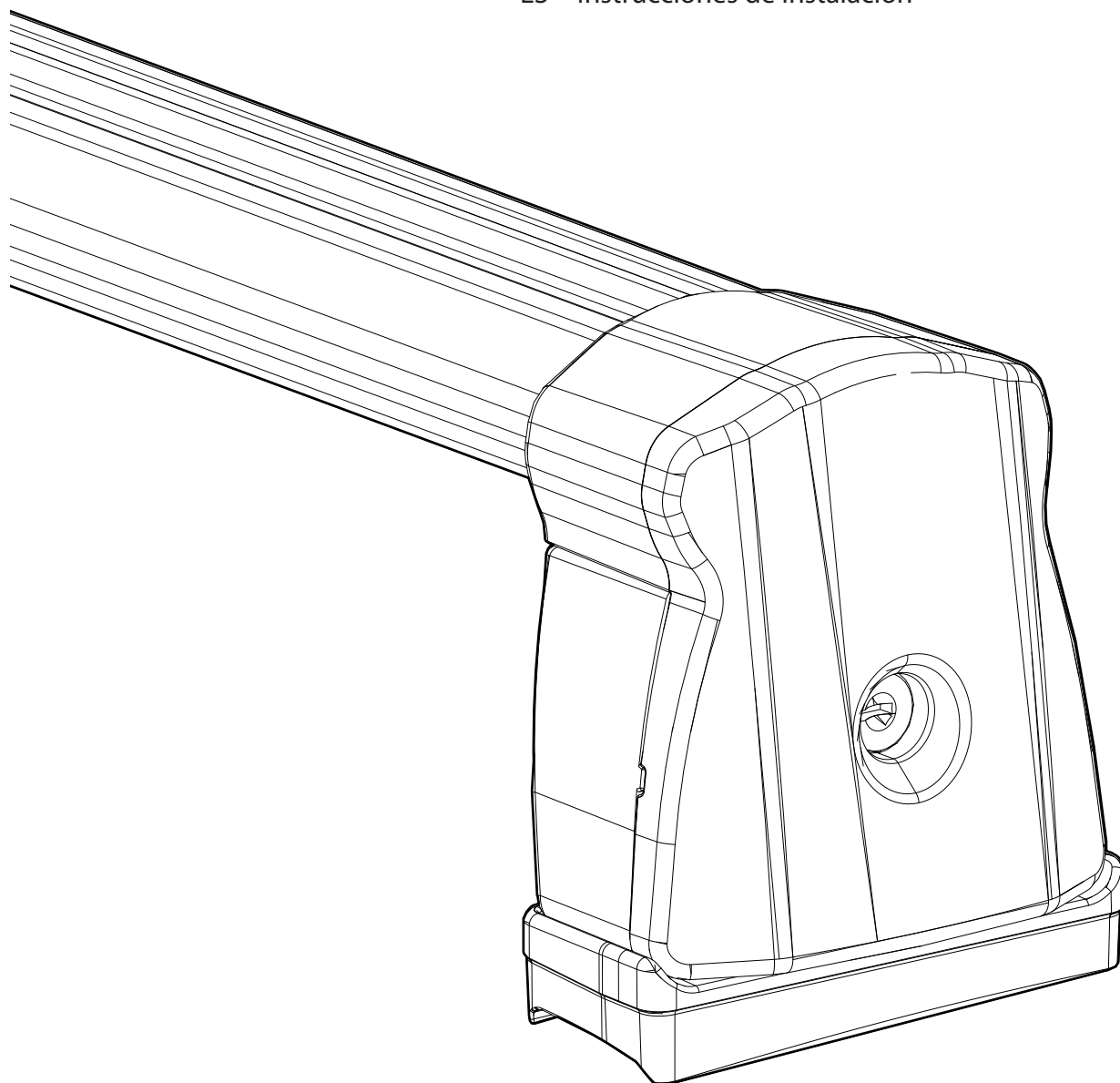









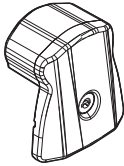



EN Installation instructions
FR Instructions de montage
ES Instrucciones de instalación

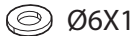

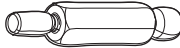

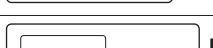
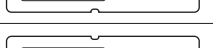



Made in Italy

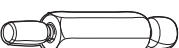

EN) Check the presence of all the components before proceeding with the installation.
 FR) Vérifiez la présence de tous les composants avant de procéder à l'installation.
 ES) Verifique la presencia de todos los componentes antes de continuar con la instalación.

N	[EN]Components (Included) [FR]Composants (Comprises) [ES]Componentes (Incluido)	Q
1		2
2		4
3		4
4		1
5		1
6		1
7		1
8	 M6X20	8
9	 Ø6X12	12
10	 M6	12
11		4
12	 FL	1
13	 FR	1
14	 RL	1
15	 RR	1
16	 5mm/2"	1
17		1
18	 XXXX	4

N	[EN]Spare Parts (Made to order) [FR]Pièces de rechange (Sur commande) [ES]Piezas de recambio (Previa solicitud)	Q	Code-Code-Código
8	 M6X20	8	700040100000
9	 Ø6X12	12	
10	 M6	12	
11		4	
16	 5mm/2"	1	700025000000
18	 XXXX	2	700010300000
A		2	700007900000
B		4	000084800000

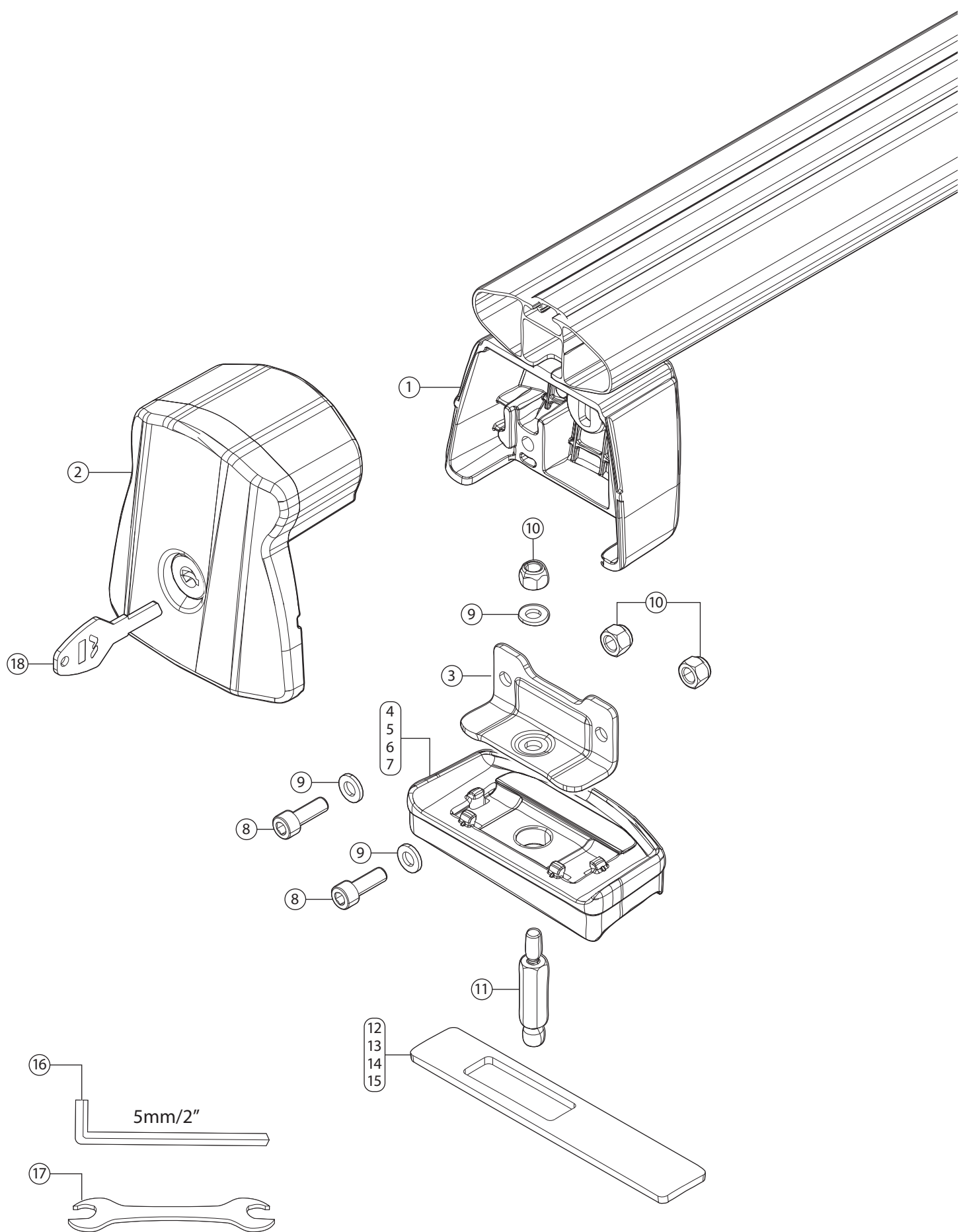

1

EN) Remove the covers covering the fix points on the rails and keep them for possible future use.
ATTENTION: The **FL** position refers to the front left fixpoint shown in the scheme.

FR) Retirez les couvercles recouvrant les points de fixation sur les rails et conservez-les pour une éventuelle utilisation future.
ATTENTION: La position **FL** fait référence au point fixe avant gauche montré en le schéma du dessin.

ES) Retire las tapas que cubren los puntos de fijación en los rieles y consérvelas para un posible uso futuro.
ATENCIÓN: La posición **FL** se refiere al punto de fijación delantero izquierdo mostrado en el esquema.

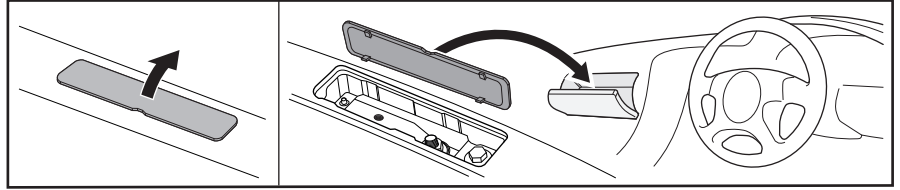
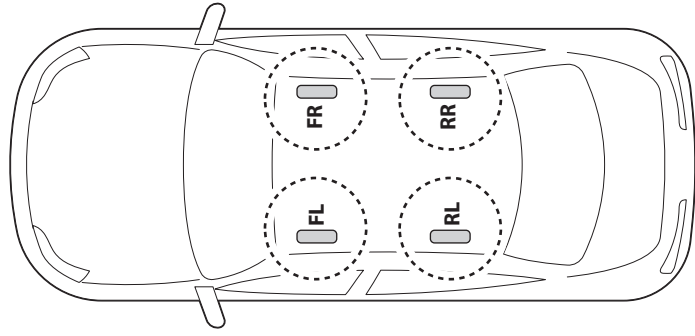

2

x4

N	Q
11	1
17	1

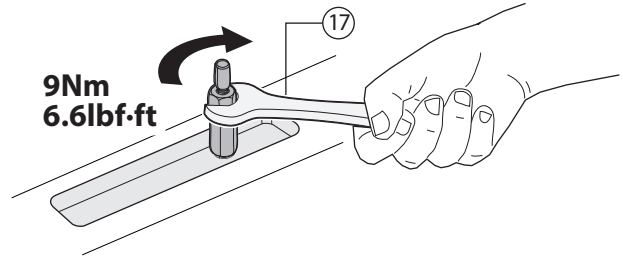
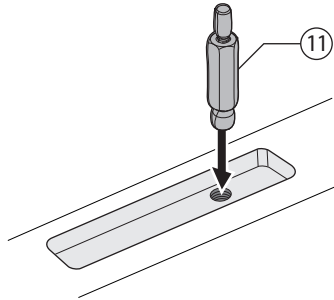

3

EN) Place the special covers supplied strictly following the scheme of the drawing below.
FR) Placer les couvercles spéciaux fournis en suivant strictement le schéma du dessin ci-dessous.
ES) Coloque las tapas especiales suministradas siguiendo estrictamente el esquema de abajo.

N	Q
12	1
13	1
14	1
15	1

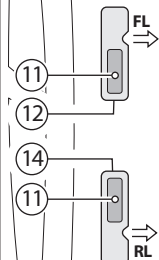
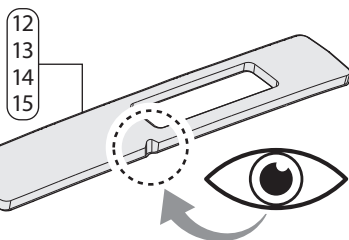
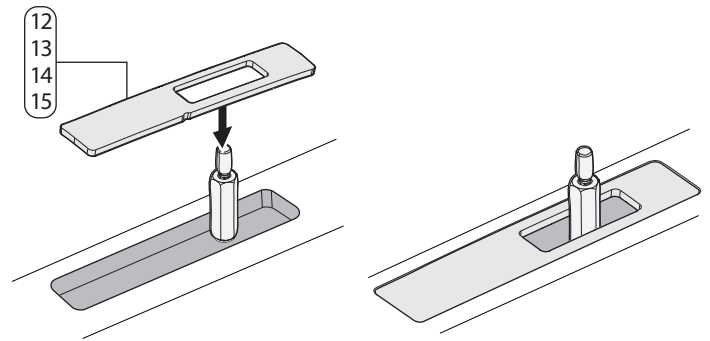
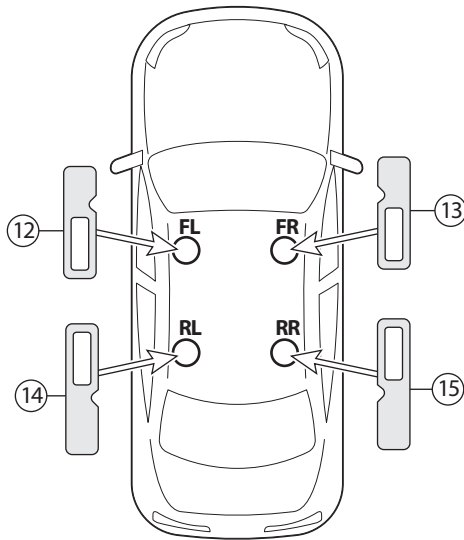





OK

NO!

4

x4

N		Q
3		4
4		1
5		1
6		1
7		1

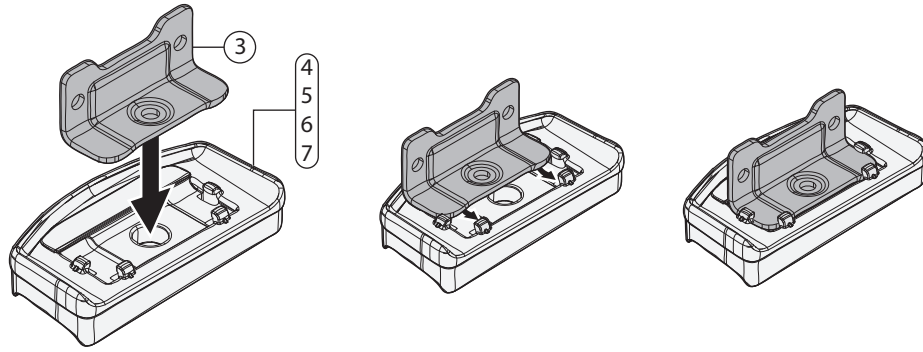

EN) ATTENTION: Check the correct positioning as shown in the diagram. The **FL** position refers to the front left fixpoint.

FR) ATTENTION: Vérifiez le bon positionnement comme indiqué sur le schéma. La position **FL** fait référence au point fixe avant gauche.

ES) ATENCIÓN: Verifique el posicionamiento correcto como se muestra en el diagrama. La posición **FL** se refiere al punto de fijación delantero izquierdo.

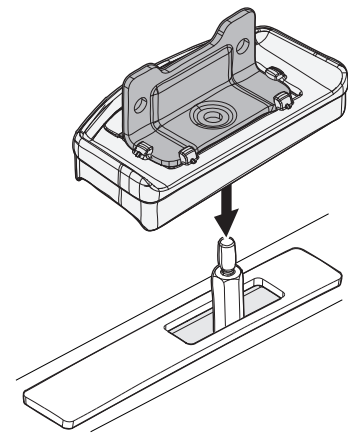
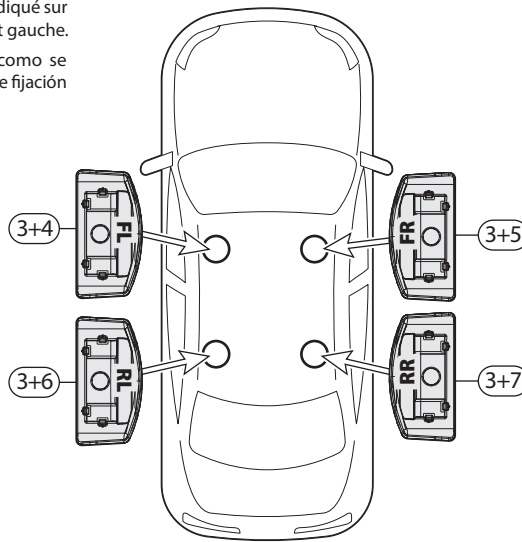
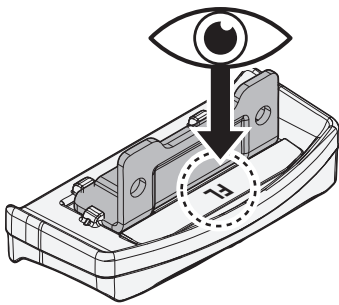

5

EN) Identify the indication **FL** under the front bar (longer bar) and place it in the relative position, front left, on the car roof.

FR) Identifier l'indication **FL** sous la barre avant (barre plus longue) et la placer dans la position relative, avant gauche, sur le toit de la voiture.

ES) Identifique la indicación **FL** debajo de la barra delantera (barra más larga) y colóquela en la posición relativa, delantera izquierda, en el techo del automóvil.

N		Q
1		2

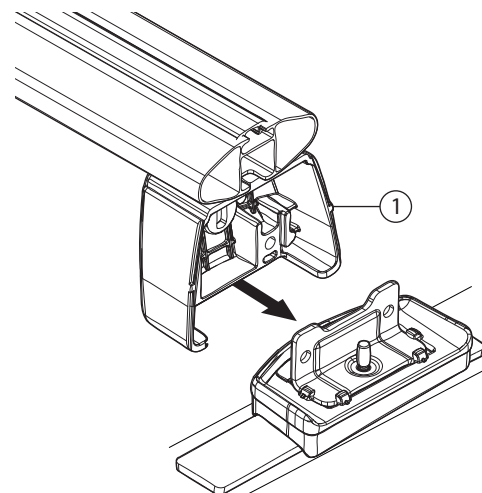
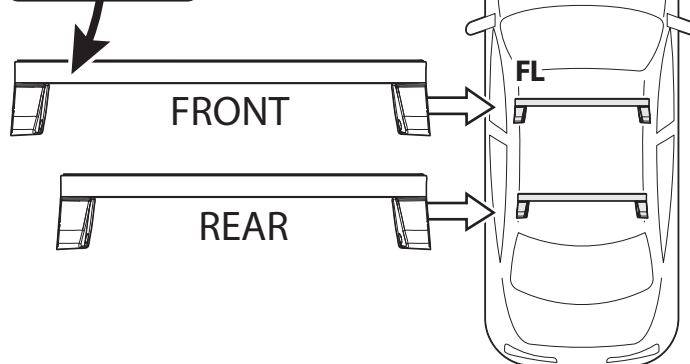
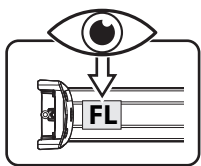
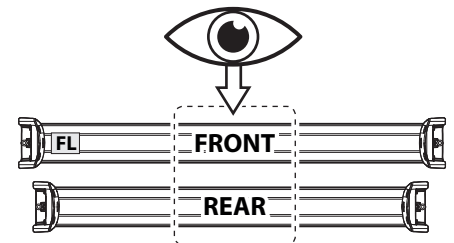
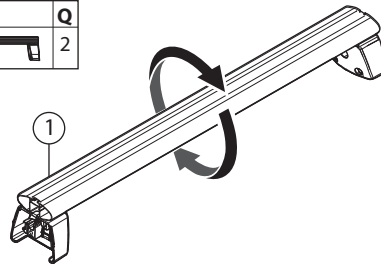

7

EN) Tighten the screws manually before proceeding with the final tightening.
 FR) Serrez les vis manuellement avant de procéder au serrage final.
 ES) Apriete los tornillos manualmente antes de continuar con el apriete final.

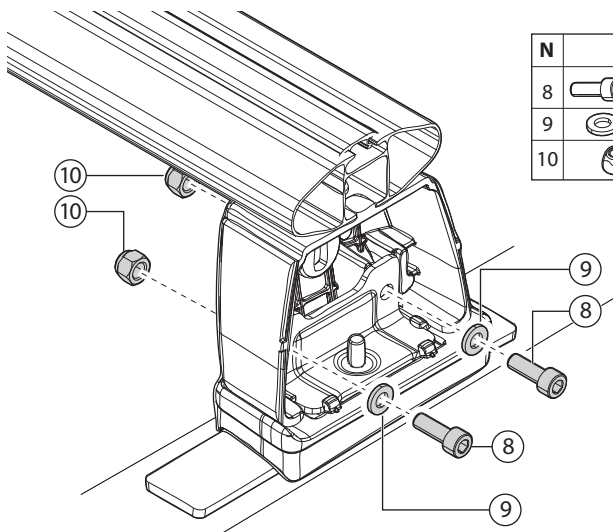

N		Q
8	M6X20	2
9	Ø6X12	2
10	M6	2

EN) To facilitate assembly, keep the nut pressed in the dedicated seat.
 FR) Pour faciliter l'assemblage, maintenez l'écrou enfoncé dans le siège dédié.
 ES) Para facilitar el montaje, mantenga presionada la tuerca en el asiento específico.

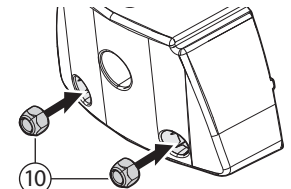

EN) ATTENTION: Proceed with the tightening of the screws following the sequence shown in the figure.
 FR) ATTENTION: procéder au serrage des vis en suivant la séquence indiquée sur la figure.
 ES) ATENCIÓN: proceda a apretar los tornillos siguiendo la secuencia que se muestra en la figura siguiente.

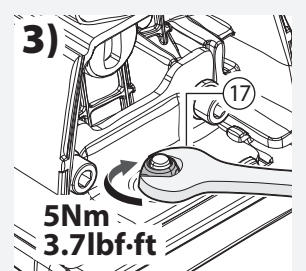
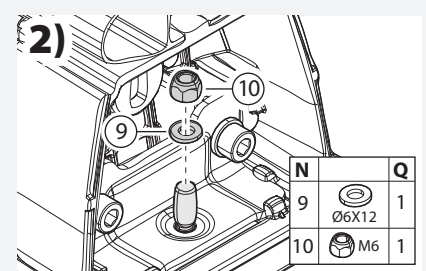
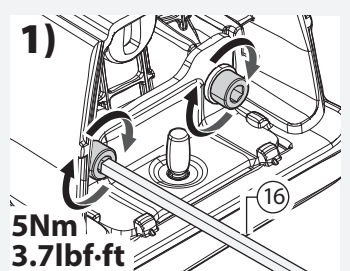



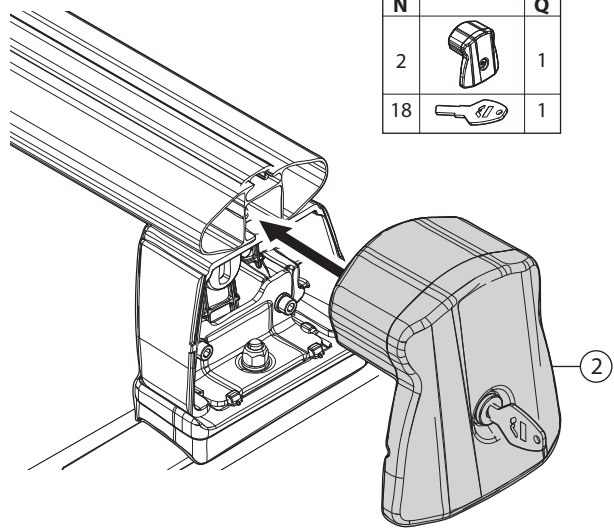
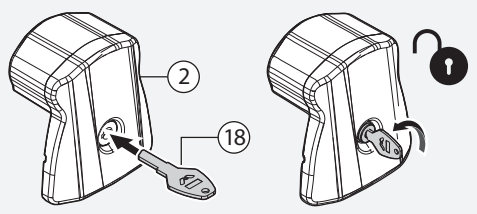

8

EN) Insert the key in the lock. Turn the key 90° counterclockwise to unlock the lock.
 FR) Insérez la clé dans la serrure. Tournez la clé de 90° dans le sens antihoraire pour déverrouiller le verrou.
 ES) Inserte la llave en la cerradura. Gire la llave 90° en sentido antihorario para desbloquear la cerradura.

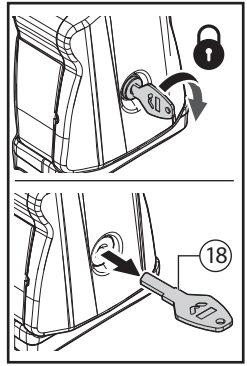

N		Q
2		1
18		1

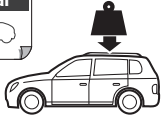
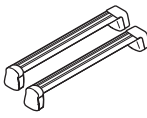

			
	Fix point bar kit	4,3kg / 9.5lb	MAX 75kg / 165lb

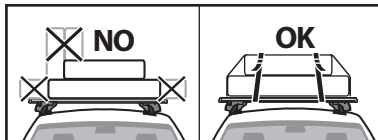

(EN) Load must be uniformly distributed with the lowest possible center of gravity. Load should not substantially extend beyond the loading surface of the roof rack. Ensure load stays within the perimeter delimited by the rack feet attached to the rails.

(FR) La charge doit être uniformément répartie en gardant le centre de gravité le plus bas possible. La charge ne doit pas dépasser significativement de la surface de charge en vous assurant que la charge ne dépasse pas le périmètre délimité par les pieds des barres.

(ES) La carga debe estar uniformemente distribuida con el centro de gravedad lo más bajo posible. La carga no debe sobrepasar sustancialmente la superficie de carga de la barra de techo.

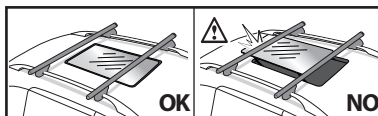

(EN) Do not open the sun roof while the bars are still mounted on the roof of the vehicle.

(FR) Ne pas utiliser le toit-ouvrant lorsque les barres sont montées sur le toit du véhicule.

(ES) No abrir u operar el techo abrible cuando las barras estén instaladas en el techo del vehículo.

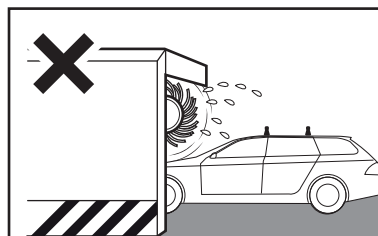

(EN) Always remove the roof bars before running your vehicle through a car wash.

(FR) Retirez toujours les barres de toit avant de faire passer votre véhicule dans un lave-auto.

(ES) Desmonte siempre las barras de techo antes de pasar por un lavadero de autos.

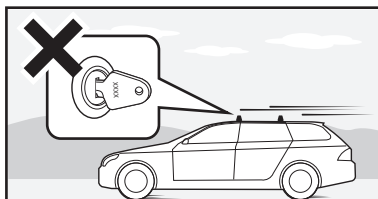

(EN) Always remove the key from the lock before driving. An inserted key may result in accidental openings and consequent load losses, causing damages and wounds, or even death, to those around you.

(FR) Retirer toujours la clé de la serrure avant de démarrer. Une clé insérée pourrait causer des ouvertures accidentelles, avec pertes de la charge en causant dommages et blessures, ou même la mort, des personnes autour de vous.

(ES) Siempre retiren la llave de la cerradura antes de partir. Una llave insertada puede causar aperturas accidentales con pérdida de la carga y causando daños y heridas y hasta la muerte de las personas cercanas.

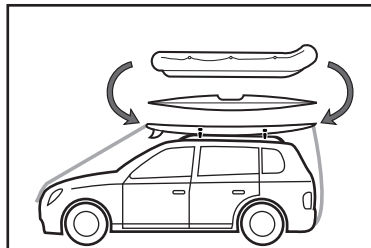

(EN) Any load extending over the windshield (except roof baskets) must be secured to both the front and rear of the vehicle, in addition to the rack. Failure to do so may result in property damage, personal injury or death.

(FR) Une charge qui dépasse le pare-brise (à l'exception des galeries) doit obligatoirement être arrimée à l'avant et à l'arrière du véhicule, en plus du système des barres. Le défaut de se conformer à cette exigence pourrait provoquer des dommages, des blessures ou même la mort.

(ES) Las cargas que sobresalen del parabrisas (excepto las cajas para equipaje) deben amarrarse a las partes delantera y trasera del vehículo, así como al portaequipaje. De no hacerlo, se pueden ocasionar daños a la propiedad, lesiones o incluso la muerte.

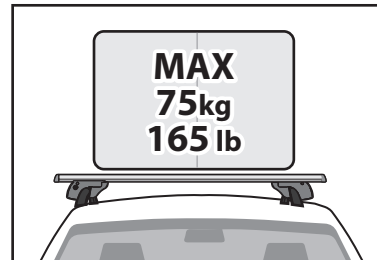

(EN) Do not exceed the maximum load specified for the roof rack, accessory rack or the maximum load recommended by the vehicle manufacturer. **Max roof load = weight of the complete roof rack system + weight of the load**

(FR) Ne pas dépasser la charge maximale spécifiée pour le porte-bagage, les accessoires du système de transport, ou la charge maximale recommandée par le constructeur du véhicule. **Charge maximale sur le toit = poids du système des barres + poids de la charge.**

(ES) No exceda la carga máxima especificada para el portaequipaje para techo y de los portaequipajes adicionales, o la carga máxima recomendada por el fabricante del vehículo. **Carga máxima del techo = peso del portaequipaje para techo + peso de la carga.**

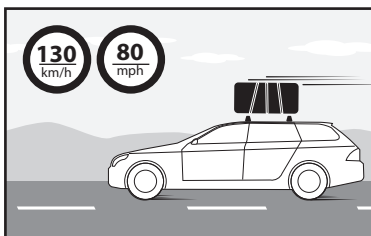

(EN) Do not exceed a speed of 130km/h (80mph).

(FR) Ne dépassez pas une vitesse de 130km/h (80mi/h).

(ES) No supere los 130km/h (80 mph) de velocidad.

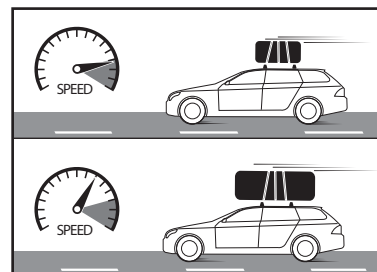

(EN) Adjust the speed according to the load.

(FR) Réglez votre vitesse en fonction de la charge.

(ES) Regulen la velocidad según la carga.

F.lli Menabò S.r.l.
Via 8 Marzo, 3
42025 Cavriago (RE) ITALY
customercare@flli-menabo.it
www.menabocaraccessories.com

Cod.istr	Data
500034800000	03/03/2022